

Merchandise Cart

CC-2PC: Program Cart

Besides our innovative food and beverage carts, we also offer a complete line of merchandise carts that will enhance the sales appeal of any type of goods.

Standard Features:

- Laminate body panels
- 6" casters on steel frame (2 swivel w/ side brakes, 2 rigid)
- Open storage
- Steel operator deck
- Sintra header panel
- Stainless steel header poles
- Black rubber caster skirt

Optional Features:

- Custom graphics
- Lighting for sign



Program Cart shown with custom graphic panels and header.

Merchandise Cart

CC-2PC: Program Cart

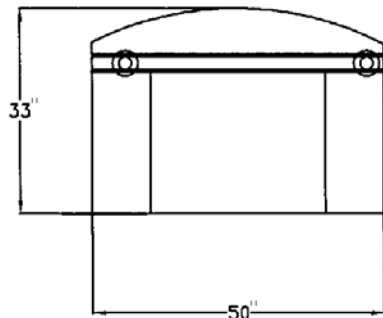

Top View

NOTE: Actual power to be determined by equipment/options.

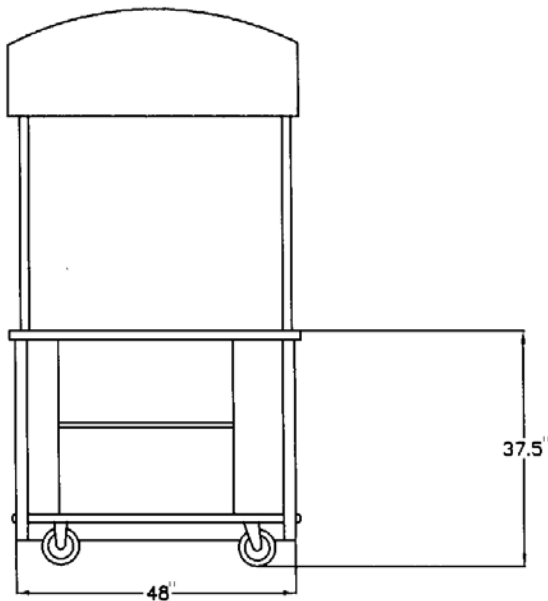

Operator's Side View

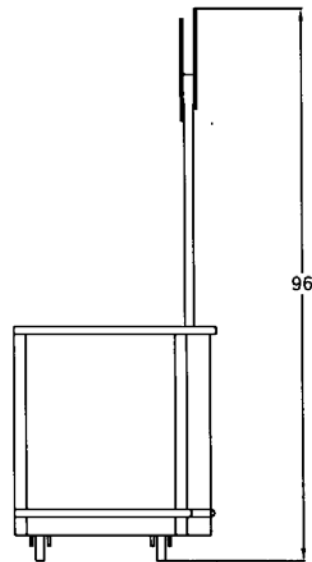

End View

The dimensions given are reference dimensions only. Critical dimensions should be brought to the attention of the salesperson. Due to a continuous program of product improvement, Carts of Colorado reserves the right to make product changes without notice.

Installation of electrical at site not included. Buyouts provided by others do not include electrical outlets unless specified on drawing. Electrical of over 120 volts/20 amps does not include cord or cap.

This document contains information that is confidential and proprietary to Carts of Colorado and shall not be reproduced or transferred to other documents or disclosed to others or used for any purpose other than that for which it was obtained without the expressed written consent of Carts of Colorado.

It is recommended that local building, health and zoning codes be researched prior to ordering. Due to a continuous program of product improvement, Carts of Colorado reserves the right to make changes in design and in specifications without notice.

5420 S. Quebec St.
Suite 204
Greenwood Village, CO 80111
(303) 329-0101
(800) 227-8634
Fax: (303) 329-6577
www.cartsofcolorado.com
sales@cartsofcolorado.com